

# MLG45PDB

MAYTAG® COMMERCIAL  
DEPENDABLE CARE®  
MULTI-LOAD STACK DRYER



## LEGENDARY MAYTAG DEPENDABILITY

Maximizing your equipment investment for over a half century.

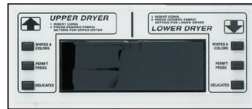

## MICROPROCESSOR CONTROLS

Maytag® Computer Trac® controls let you adjust prices by cycle, day and time—and they provide simple one-touch cycle selection.

## BUILT LIKE A TANK

The MLG45PDB is one of the heaviest 45-pound stack dryers on the market, offering years of dependable Maytag performance.

## FOR YOUR CUSTOMERS:

- Fast-Drying Axial Airflow System
- ThermoGuard™ System Helps Prevent Laundry Overheating
- Extra-Large Door Openings
- Time Remaining Digital Display
- Microprocessor Controls

## FOR YOUR OPERATION:

- Single Coin Box For Both Dryers
- Front Access For Easier Self Service
- Two 8" Vents Or One Optional 10" Vent
- 2 Large-Capacity Lint Drawers

## BUILT-TO-LAST™ FEATURES:

- Heavy-Duty Enclosed Motors
- Permanently Lubricated Bearings
- Rear Belt Drive System
- 5-Year Limited Warranty—All Parts Covered



LAUNDRY SOLUTIONS  
YOU CAN *DEPEND* ON.

THERMOGUARD™ SYSTEM  
PROTECTS LAUNDRY  
AGAINST OVERHEATING

visit [maytagcommerciallaundry.com](http://maytagcommerciallaundry.com)  
or call 800-662-3587



## OUR COMMITMENT TO DEPENDABLE QUALITY

At Maytag, we believe durable goods should remain just that. That's why every Maytag® product is constructed of the highest-quality materials and with the utmost in precision craftsmanship. It's also why we stand behind our equipment with solid service and support from our professional Maytag laundry suppliers. Simply put, when you choose Maytag® products, you ensure your peace of mind.



## MLG45PDB

MAYTAG® COMMERCIAL  
DEPENDABLE CARE®  
MULTI-LOAD  
STACK DRYER

## Maytag® Commercial Dependable Care® Multi-Load Stack Dryer

### MICROPROCESSOR COIN-DROP

DRYER SPECIFICATIONS	
<b>MODEL</b>	<b>MLG45PDB</b>
<b>MOTOR</b>	
Single-phase, thermoprotected against overload, auto-reset	•
HP (kw)	.75 (.56)
Tumble Speed — rpm	43 + 1
<b>CAPACITY</b>	
Lbs. (kg) per drying chamber	45 (20.41)
Cu. ft. (L) per drying chamber	14.6 (413.43)
<b>AIRFLOW</b>	
Cfm (cmm) per drying chamber	600 (16.99)
<b>TUMBLERS</b>	
Diameter — in. (mm)	2-32.75 (2-831.9)
Depth — in. (mm)	2-30 (2-762)
<b>DOOR OPENING DIAMETER</b>	
In. (mm)	27 (686)
<b>ELECTRICAL REQUIREMENTS</b>	120V, 60 Hz
Export Models — options available	208 – 240V/1PH or 3 PH
<b>BREAKER/FUSE REQUIREMENTS</b>	
Amps per drying chamber	15
<b>EXHAUST DUCT DIAMETER</b>	
In. (mm)	2-8 (203) or 1-10 (254)
<b>GAS RATING</b>	
BTU/hr. (kcal/hr.) per drying chamber	112,000 (28,230)
<b>GAS INLET PER POCKET</b>	
M.N.P.T. in. (mm)	1 inlet, 3/4 (19)
<b>ADJUSTABLE LEVELING LEGS</b>	•
<b>COLORS</b>	
White	•
Stainless Steel	•
<b>APPROXIMATE WEIGHT</b>	
Crated — lbs. (kg)	1080 (490)
Uncrated — lbs. (kg)	1015 (460)
<b>DIMENSIONS</b>	
Height — in. (mm)	81 (2057)
Width — in. (mm)	34.25 (870)
Depth — in. (mm)	52.5 (1334)
Door opening diameter — in. (mm)	27 (686)

See specific instructions for proper installation.  
Because of continuous product improvement, Maytag reserves the right to change specifications without notice.

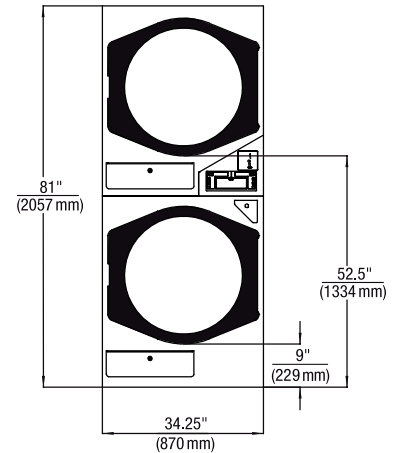

FRONT VIEW

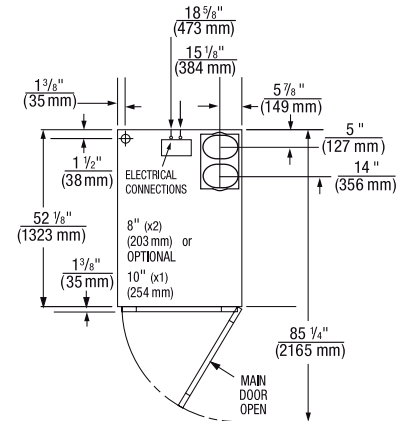

TOP VIEW

\*Dimensions will vary according to adjustment of leveling legs; add 1/2" (13 mm) minimum.



NEW YORK CITY  
M.E.A.



## 5-YEAR LIMITED WARRANTY ALL PARTS COVERED

For a period from the date of original purchase through the time listed above, the designated parts that fail in normal commercial use will be repaired or replaced free of charge for the part itself, with the owner paying all other costs, including labor, transportation and customs duty. Chemical damage is excluded from all warranty coverage. See complete warranty for details.